

R&S® CMW500

Wideband Radio Communication Tester

RF production testing



R&S®CMW500

Wideband Radio Communication Tester

At a glance

The R&S®CMW500 is a compact solution for fast and precise production testing of current and future wireless devices from basic mobile phones to the most sophisticated PDAs. The multitechnology platform allows users to implement the concept of a lean production line from start to finish: A single measuring instrument covers all RF test requirements.

The R&S®CMW500 unites three basic functions in one box: RF generator, RF analyzer and signaling (network emulation). As a result, it can be flexibly used in all stages of production – from calibration and verification to functional testing. The extreme scalability, test speed and measurement accuracy translate into minimum test costs. The compact tester approach with SCPI remote control concept minimizes the effort involved in planning and upkeeping production test systems.

Key facts

- ▀ Base model: general-purpose RF power meter and CW generator with List modes for fast calibration¹⁾ of wireless devices
- ▀ Vector signal analyzer (VSA) for transmitter verification¹⁾
- ▀ Vector signal generator (VSG) for receiver testing
- ▀ Signaling (network emulation) for functional testing
- ▀ Reference RF power measurement enabled by direct connection of R&S®NRP-Zxx power sensors
- ▀ Easy connection to wireless devices with complex RF architecture by using the integrated RF interface
- ▀ State-of-the-art graphical user interface (GUI)
- ▀ SCPI remote control via LAN/GPIB interface
- ▀ Ready for LXI Class C
- ▀ Process controller with Windows® XP operating system

¹⁾ For explanations, see glossary at end of brochure.



R&S®CMW500

Wideband Radio Communication Tester

Benefits and key features

Just one 19" box for all technologies

- ▮ Support of cellular and non-cellular wireless technologies as well as of broadcast technologies
 - ▮ Slim solution for the production of wireless multimode devices
- ▷ [page 4](#)

Just one scalable hardware

- ▮ Future-ready RF parameters
 - ▮ Scalable RF resources
 - ▮ Configurable baseband and signaling units
- ▷ [page 5](#)

Drastically reduced test costs; alignment up to ten times faster

- ▮ R&S®Multi-Evaluation transmitter measurements
 - ▮ R&S®Smart Alignment¹⁾ concept
- ▷ [page 6](#)

Optimized handling for production test systems

- ▮ Minimum user risk owing to all-in-one architecture
 - ▮ Comprehensive RF frontend eliminating the need for external hardware
 - ▮ Optimum handling through Press&Go applications
- ▷ [page 8](#)

Designed for high first pass yield

- ▮ High absolute accuracy plus repeatability and linearity
 - ▮ Precise reference measurements by connecting R&S®NRP-Zxx power sensors
- ▷ [page 10](#)

Minimum floor space

- ▮ Dual tester configuration
 - ▮ R&S®CMW280 wideband radio communication tester
- ▷ [page 11](#)

Reduced operating costs

- ▮ Selectable calibration interval of 12 or 24 months
- ▷ [page 12](#)

Just one reliable T&M partner

- ▮ Rohde&Schwarz actively participates in the evolution of wireless communications standards
 - ▮ Rohde&Schwarz offers optional services to increase the value of the R&S®CMW500
 - ▮ Rohde&Schwarz is the leading manufacturer of T&M equipment for wireless standards and provides a complete test portfolio from a single source
 - ▮ Worldwide sales, application and service network
- ▷ [page 13](#)

"WiMAX Forum" is a registered trademark of the WiMAX Forum. "WiMAX," the WiMAX Forum logo, "WiMAX Forum Certified," and the WiMAX Forum Certified logo are trademarks of the WiMAX Forum.

CDMA2000® is a registered trademark of the Telecommunications Industry Association (TIA - USA).

The Bluetooth® word mark and logos are registered trademarks owned by Bluetooth SIG, Inc. and any use of such marks by Rohde&Schwarz is under license.

Just one 19" box for all technologies

Support of cellular and non-cellular wireless technologies as well as of broadcast technologies

The R&S®CMW500 is the single-box radiocommunications tester that supports the largest number of technologies. It can handle both the widely used mobile radio standards (e.g. GSM and WCDMA) and new standards such as LTE. To increase the wireless device test depth, it also supports non-cellular standards such as WLAN or Bluetooth® as well as broadcast standards.

This versatility provides many advantages for the user:

- Multimode test setup cabling requires considerably less effort
- The energy consumption of the T&M equipment is lower than that of setups involving multiple measuring instruments; the air conditioning requirements are also reduced
- It is much easier to integrate a single tester into automation and remote control systems

Slim solution for the production of wireless multimode devices

The R&S®CMW500 saves space and reduces investment costs both in production and in the lab.

Use of the R&S®CMW500 for all technologies



Just one scalable hardware

Future-ready RF parameters

Two independent transmit and receive paths in the frequency range up to 6 GHz and a transmit bandwidth of 80 MHz/receive bandwidth of 40 MHz make the R&S®CMW500 perfect for today's and tomorrow's requirements. A high output dynamic range of 128 dB and sensitive inputs reduce the need for external amplifiers or attenuators.

Scalable RF resources

Depending on the application, one or two RF paths consisting of RF converters and frontends are used. The front-end enables the direct connection of wireless devices with complex RF architecture.

The R&S®CMW500 is therefore fit for the following tests:

- Tests of MIMO-capable DUTs
- Parallel test of two DUTs with the same technology
- Parallel test of two technologies in one DUT

Configurable baseband and signaling units

A maximum of two analyzer modules combined with ARB baseband generators are used in the non-signaling mode. In addition, multiple signaling units can be integrated to provide the network emulation for signaling and protocol tests.

Block diagram of the R&S®CMW500

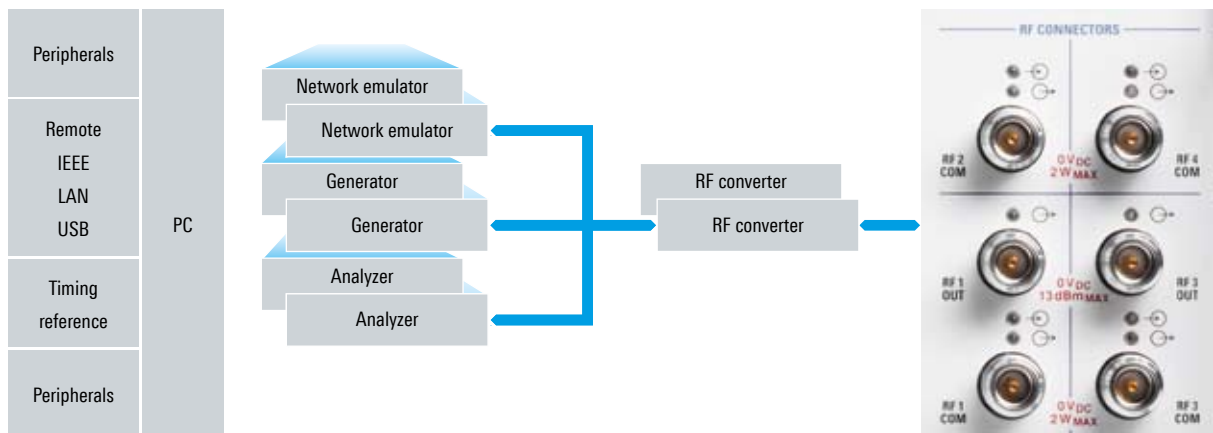

Drastically reduced test costs; alignment up to ten times faster

Ongoing technological innovation and the ever-rising number of bands that must be supported increase the complexity of state-of-the-art wireless devices. The test effort multiplies, and the production costs rise. For these reasons, finding new, time-saving alignment approaches is essential. Rohde&Schwarz offers a significant reduction of test times compared to conventional methods by means of R&S®Multi-Evaluation¹⁾ TX measurements and its R&S®Smart Alignment¹⁾ non-signaling concept. The R&S®CMW500 all-in-one architecture¹⁾ with built-in analyzer and generator provides the fastest possible transmit-receive interaction and is the optimum solution for time-critical tests in production.

R&S®Multi-Evaluation: LTE TX measurement.

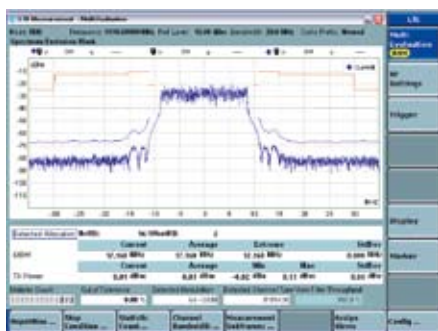
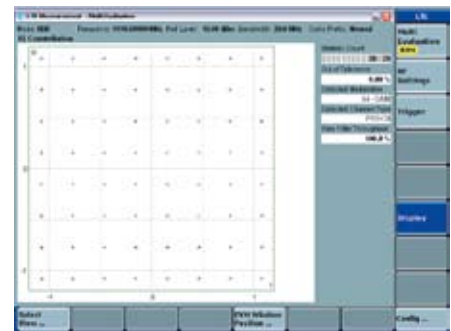
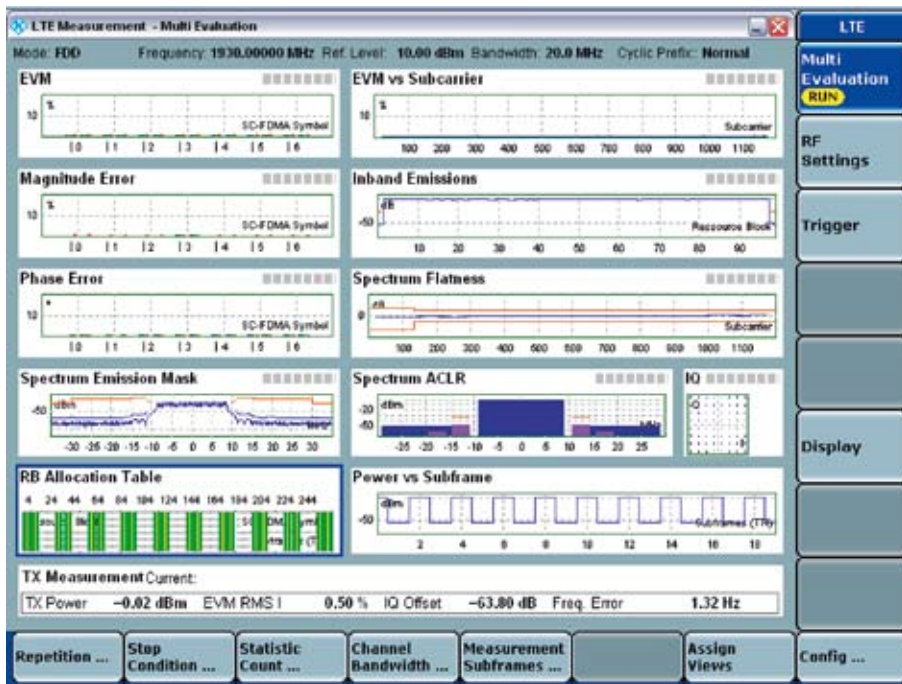

R&S® Multi-Evaluation transmitter measurements

- Different evaluations (power, time mask, modulation quality, spectrum, code domain) can use an identical sampling data set
- Time-overlapped data capturing and evaluation
- Enhanced speed by switching off evaluations that are not required

This approach not only increases the test speed in comparison with purely sequential data capturing and evaluation but also ensures greater test depth. This results in a more detailed overview of the transmitter functions, since all measured parameters are correlated.

R&S® Smart Alignment concept

- Fully automatic frequency and level switching with general-purpose RF generator and power meter in List mode
- R&S® Multi-Evaluation List mode¹⁾ helps ensure fast transmitter verification
- Simultaneous transmitter and receiver alignment, if supported by the DUT¹⁾
- Extensive trigger functions for analyzer/generator
- Statistical evaluation included

Preconfigured identical test sequences in the DUT¹⁾ and the tester minimize the volume of communications inside the test system, which is the bottleneck of conventional approaches. Flexible R&S®CMW500 parameterization facilitates adaptation to the test philosophy of the wireless device under test and speeds up transfer to mass production.

Optimized handling for production test systems

The R&S®CMW500 is a turnkey solution that can start testing immediately after delivery. The fully integrated tester with calibrated RF paths and Press&Go¹⁾ applications simplifies generating and updating test sequences and production test systems. The all-in-one architecture¹⁾ ensures maximum test performance plus minimum footprint and optimum power consumption. This concept for minimizing test costs comes from a company that has been successfully supplying solutions for the production of wireless devices for more than 30 years: Rohde&Schwarz.

Minimum user risk owing to all-in-one architecture

- Built-in vector signal analyzer and generator as well as signaling
- SCPI remote control via LAN or GPIB interface
- Windows® XP operating system
- Remote control via Windows® Remote Desktop
- Connectors for mouse, keyboard and external monitor
- Internal TCXO or OCXO timebase and 10 MHz reference frequency output
- External reference frequency (alternative)
- Fully automatic RF path correction concept¹⁾ of frequency, temperature and level in realtime
- Completely calibrated solution
- Completely standard-conforming EMC¹⁾ characteristics
- Matched power supply

The turnkey solution provides assured measurement accuracy without the user's constant attention. Time- and cost-intensive repetitive self-alignment procedures can be omitted.

The comprehensive RF frontend eliminates the need for external hardware (dual-tester front panel).



Comprehensive RF frontend eliminating the need for external hardware

- ▮ Flexible RF interface for direct connection of wireless devices with complex RF architecture
- ▮ Alternative: simultaneous connection of two wireless devices with one antenna each (connectors RF1 COM and RF2 COM)
- ▮ Entirely integrated into R&S®CMW500 path correction concept¹⁾
- ▮ Flexible path configuration via GUI¹⁾
- ▮ Optimized for mass tests in production
- ▮ Snap-N female connector RF1 OUT: RF output
- ▮ Snap-N female connector RF1 COM: combined RF input/output
- ▮ Snap-N female connector RF2 COM: combined RF input/output

The handling time for sequential testing of two wireless devices is reduced. The test system costs decrease while reliability and accuracy increase, since additional RF components are not required.

Optimum handling through Press&Go applications

- ▮ Highly automated measurements at the press of a button
- ▮ Preconfigured in line with specifications of the selected technology
- ▮ Extensive statistical evaluations of measurement results already implemented

Technology-specific measurement results are output; no need to bother with time-consuming details such as calculation, limits, or statistics.

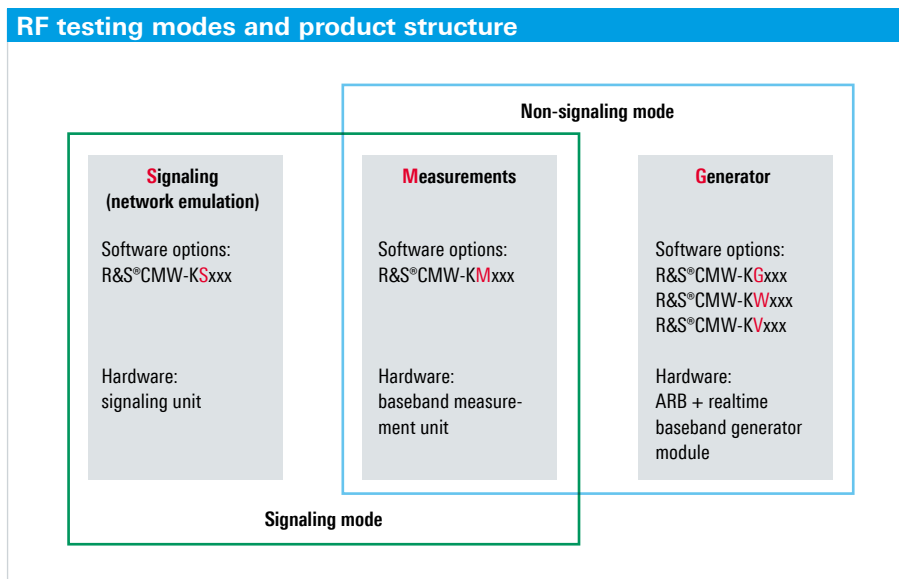

Designed for high first pass yield

High absolute accuracy plus repeatability and linearity

The R&S®CMW500 has been specially designed for production applications: Top priority was placed on accuracy, repeatability and linearity. These parameters have a direct influence on the production yield. The higher the accuracy of these parameters, the lower the number of DUTs that are classified as faulty although they comply with specifications. Internal temperature sensors automatically adapt the measurement accuracy to the ambient conditions. It is not necessary to perform a calibration when temperatures vary or when the instrument is switched on.

Precise reference measurements by connecting R&S®NRP-Zxx power sensors

Highly accurate RF power measurements at any point in the test setup make it possible to optimize test procedures in production. It is possible to connect an R&S®NRP-Zxx power sensor directly to the R&S®CMW500 for reference measurements.



Test setup for reference measurements with an R&S®NRP-Zxx power sensor and an R&S®NGMO2 power supply.

Relevant R&S®CMW500 RF power meter parameters

Level uncertainty		< 0.50 dB, typ. < 0.30 dB
Level repeatability	input level ≥ -40 dBm	typ. < 0.01 dB
Level linearity with fixed expected nominal power setting	level range 0 dB to -40 dB	typ. < 0.15 dB

Relevant R&S®CMW500 generator parameters

Output level uncertainty	output level > -120 dBm	< 0.60 dB, typ. < 0.36 dB
Output level repeatability	output level < -80 dBm	typ. < 0.05 dB
Output level linearity with fixed RF output attenuator setting	output level range -130 dBm to -5 dBm, GPRF generator List mode, level range 0 dB to -30 dB	typ. < 0.15 dB

Minimum floor space

Dual tester configuration ¹⁾

The R&S®CMW500 can optionally be configured as a dual tester. This configuration includes dual test resources so that two identical wireless devices can be tested simultaneously in the non-signaling mode. This approach saves valuable floor space in the production hall.

R&S®CMW280 wideband radio communication tester

The R&S®CMW280 is the compact version of the R&S®CMW500 and has 20% less depth. The instrument can be configured exclusively as a single tester and requires only minimum floor space in classic test concepts.

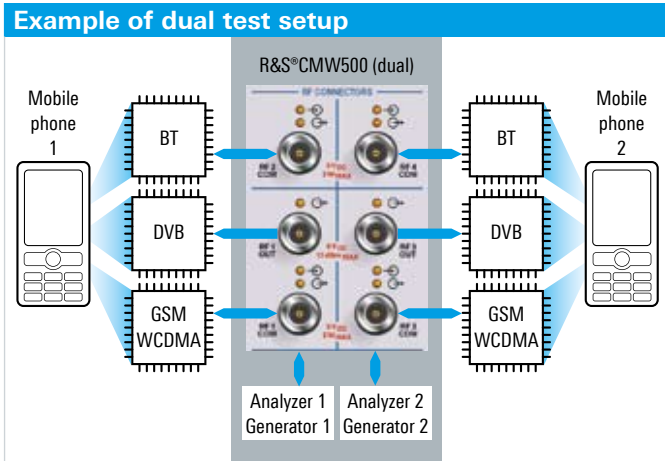

The R&S®CMW280 is the compact version of the R&S®CMW500 and has 20% less depth.

Differences between the R&S®CMW500 and the R&S®CMW280		
	R&S®CMW500	R&S®CMW280
Testing capability	1 DUT, optionally 2 DUTs simultaneously in non-signaling mode	1 DUT
Dimensions (W × H × D)	465.1 mm × 197.3 mm × 517.0 mm (18.3 in × 7.8 in × 20.4 in)	465.1 mm × 197.3 mm × 417.0 mm (18.3 in × 7.8 in × 16.4 in)
Weight with typical options	approx. 18 kg (approx. 40 lb)	approx. 14 kg (approx. 31 lb)
Remote control interfaces		
Front panel		
LAN	1	–
Rear panel		
LAN	1	1
IEEE 488	option	option
USB type B	1	–

Reduced operating costs

Selectable calibration interval of either 12 or 24 months

Users can optimize costs to achieve high absolute accuracy or minimum test and measurement operating costs.

Relevant R&S®CMW500 RF level uncertainty

12-month calibration interval:

- Analyzer < 0.50 dB
- Generator < 0.60 dB

24-month calibration interval:

- Analyzer < 0.70 dB
- Generator < 0.80 dB

R&S®UCS calibration system.



Just one reliable T&M partner

As the leading supplier of T&M equipment for wireless devices, Rohde&Schwarz is actively participating in 3GPP, 3GPP2 and OMA bodies to further develop the communications standards. Standardization results are immediately implemented in the company's T&M equipment, which incorporates decades of experience in wireless communications.

With its dense worldwide support and service network, Rohde&Schwarz helps users to efficiently employ the R&S®CMW500 and achieve maximum benefit and maximum ROI.

Rohde&Schwarz offers the following optional services:

- Calibration and hardware maintenance
- Extended warranty
- Automatic software upgrade services
- Fast, expert technical support by application engineers
- User and technology training

Rohde&Schwarz offers the R&S®CMW500 radiocommunications tester and also additional T&M equipment for wireless devices such as signal generators and signal analyzers. Hardware and software are optimally adapted to each other because they come from a single source.



Application

Production test on wireless devices with the R&S®CMW500

Economically produced RF chips exhibit variations in frequency and level characteristics. The following test procedure must be applied during the production of wireless devices:

Step 1: Calibration. Deviations from the ideal values for transmitter and receiver must be measured, interpolated and stored in correction tables.

Step 2: Verification of transmit and receive parameters.

Step 3: Functional testing of the assembled wireless device.

This is the only way to ensure that the specifications of the relevant technology standard will be complied with later during operation in the network and that the wireless device will operate reliably.

Irrespective of the preferred test concept, the R&S®CMW500 can be used for all three production steps as follows:

Calibration must be performed in the non-signaling mode because the DUT has not yet been calibrated and signaling procedures cannot yet be supported. At this stage, the generator/analyzer functionality of the R&S®CMW500 comes into its own.

Depending on the chipset used, verification can be performed in the non-signaling or in the signaling mode. The following R&S®CMW500 functionalities are used for this step:

- Analyzer/generator (non-signaling mode)
- Analyzer/network emulator (signaling mode)

Use of the R&S®CMW500 for cellular wireless technologies			
Technology	RF generator	RF analyzer	Network emulation (signaling)
LTE FDD	•	•	•
LTE TDD (TD-LTE)	•	•	•
Mobile WiMAX™	•	•	•
CDMA2000® 1xRTT	•	•	•
CDMA2000® 1xEV-DO	•	•	•
TD-SCDMA	•	•	
WCDMA/HSPA+	•	•	•
GSM/GPRS/EDGE/EDGE Evolution	•	•	•

Use of the R&S®CMW500 for non-cellular wireless technologies		
Technology	RF generator	RF analyzer
GPS	•	
Bluetooth®	•	•
WLAN a/b/g/n	•	•

Use of the R&S®CMW500 for broadcast technologies		
Technology	RF generator	RF analyzer
DVB-T	•	
T-DMB	•	
MediaFLO™	•	
CMMB	•	
FM stereo radio	•	•

During the functional test at the end of the production line, the realtime behavior in the actual network is normally checked. At this stage, the R&S®CMW500 in the signaling mode is used as a network emulator.

Transmit power calibration

The R&S®CMW500 GPRF¹⁾ power measurement evaluates a list of power steps at different levels and frequencies and performs statistical evaluation. A wide range of IF filters is available:

- Gaussian filters, selectable bandwidths between 1 kHz and 10 MHz
- Bandpass root-raised-cosine (RRC) filters, selectable bandwidths between 1 kHz and 40 MHz, roll-off 0.1
- WCDMA RRC filter (3GPP TS 34.121 specification), 3.84 MHz bandwidth, roll-off = 0.22
- CDMA filter (TIA/EIA/IS-2000.2-A specification), 1.4 MHz bandwidth

Transmitter verification

The R&S®CMW500 offers the widest range of precise RF measurements for wireless devices (R&S®CMW-KMxxx options), including multiple different measurements of the following parameters:

- Power
- Modulation quality
- Spectrum
- Code domain

The R&S®Multi-Evaluation approach enables different analyses of the same data sample. The R&S®Multi-Evaluation List mode (R&S®CMW-KM012 option) is a consistent implementation of the R&S®Smart Alignment concept (predefined test sequences) for transmitter verification.

Inner loop power control testing

The R&S®CMW500 is able to carry out this test in the relevant technologies (R&S®CMW-KMxxx options). As a prerequisite, the DUT must be stimulated using the R&S®CMW500 generator or the signaling function.

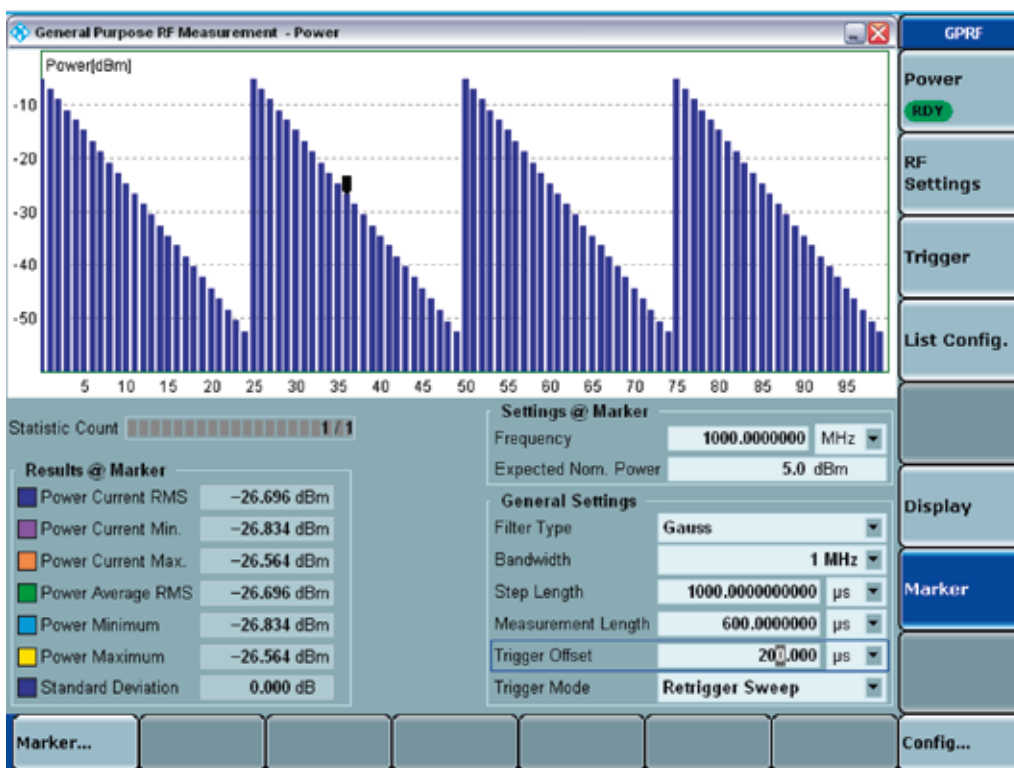

General-purpose RF power measurement menu.

Calibration of receiver signal strength indication (RSSI)¹⁾

The R&S®CMW500 enables the following calibration scenario:

The GPRF¹⁾ generator in List mode can be operated with preconfigured levels and frequencies. The precalculated baseband signal, which is stored in the ARB¹⁾ memory, can be provided with markers that stepwise switch the list of the GPRF¹⁾ generator.

Multisegment waveforms and marker-triggered GPRF¹⁾ generator lists are prerequisites for minimum ARB¹⁾ setup times and fast RSSI¹⁾ calibration scenarios.

Receiver verification in non-signaling mode

The receiver is checked for technology-specific absolute sensitivity and maximum input level.

This verification is based on a BER test¹⁾ with the R&S®CMW500 being used as the signal source. The ARB + realtime¹⁾ baseband generator module (R&S®CMW-B110A option) provides technology-specific signals with pilot and data channels. Depending on the applicable test requirements, the following solutions are offered:

- ARB mode¹⁾ based on precalculated R&S®WinIQSIM2™ waveforms (R&S®CMW-KWxxx options) or customer-specific waveforms
- Online mode¹⁾ for pilot channels and PRBS user data channels with high data volume (R&S®CMW-KGxxx options)

In single-ended BER testing¹⁾, the bit error ratio is evaluated in the DUT or the DUT controller.

In loop BER testing¹⁾, the data stream to be tested is routed back to the tester via the uplink. The R&S®CMW500 (R&S®CMW-KMxxx options are required) evaluates the bit error ratio of the following channels via postprocessing:

- GSM loop C
- WCDMA RMC 12.2 kbps
- TD-SCDMA RMC 12.2 kbps

The screenshot displays the 'General Purpose RF Generator 1 - Generator' software window. The 'List Configuration' menu is open, showing various settings for the generator. The 'List Mode' is set to 'On', and the 'Baseband Mode' is set to 'ARB'. The 'Baseband Configuration' section includes 'Dual Tone' and 'ARB' options. The 'List Configuration' section shows 'List Mode' as 'On', 'List Section' as 'Start Index: 0 Stop Index: 19 Result Count: 20', and 'Current Index' as '0'. The 'List' section contains a table with columns for 'Frequency', 'Level (RMS)', 'Digital Gain', 'Dwell Time', and 'Mod. On/Off'. The table lists five entries for 'List [0]' through 'List [4]', all at a frequency of 903.000000 MHz and a dwell time of 500.00000 ms. The 'Level (RMS)' values are -40.00 dBm, -50.00 dBm, -60.00 dBm, -70.00 dBm, and -80.00 dBm, respectively. The 'Mod. On/Off' column has checkboxes that are currently unchecked. The 'GPRF Generator' status is shown as 'ON' in a yellow box. The bottom of the window features a control bar with buttons for 'List Mode Off On', 'Start- / Stop Index...', 'Current Index...', 'List Submode...', 'Execute Single', and 'Fill List...'.

List	Frequency	Level (RMS)	Digital Gain	Dwell Time	Mod. On/Off
List [0]	903.000000 MHz	-40.00 dBm	0.00 dB	500.00000 ms	<input type="checkbox"/>
List [1]	903.000000 MHz	-50.00 dBm	0.00 dB	500.00000 ms	<input type="checkbox"/>
List [2]	903.000000 MHz	-60.00 dBm	0.00 dB	500.00000 ms	<input type="checkbox"/>
List [3]	903.000000 MHz	-70.00 dBm	0.00 dB	500.00000 ms	<input type="checkbox"/>
List [4]	903.000000 MHz	-80.00 dBm	0.00 dB	500.00000 ms	<input type="checkbox"/>

General-purpose RF generator configuration menu.

Receiver verification in signaling mode

Non-acknowledged mode: This verification is performed on a loop BER test ¹⁾ with the R&S®CMW500 being used as a signal source and realtime data analyzer. The device under test (DUT) loops back the data stream to be tested.

Acknowledged mode: The R&S®CMW500 sends the data stream to the receiver of the DUT. The DUT assesses reception quality and returns ACK/NACKs to the tester. The tester compares the data packets sent with the ACK/NACKs received and calculates the data block error ratio (DBLER).

Functional test with easy callbox operation

The listed cellular technologies can be executed with automatic protocol stacks to realistically emulate a network ²⁾ (signaling mode):

- GSM/GRPS/EDGE
- WCDMA
- LTE FDD
- CDMA2000® 1xRTT
- CDMA2000® 1xEV-DO
- Mobile WiMAX™

Depending on the technology used, the following procedures are performed:

- Registration
- Call setup (voice, data)

All signaling parameters are automatically selected by the R&S®CMW500, but the user can modify many of them. Local or remote operation and configuration of the network emulation are performed interactively via the user interface.

²⁾ Optional R&S®CMW-B2xxxA and R&S®CMW300A signaling units in combination with R&S®CMW-KSxxx signaling software options.



WCDMA signaling menu.

R&S®CMW-KM200 measurement personality³⁾

- ▮ Burst power
- ▮ Time mask
- ▮ I/Q origin offset/imbalance (8PSK modulation scheme)
- ▮ Error vector magnitude (8PSK modulation scheme)
- ▮ Magnitude error (8PSK modulation scheme)
- ▮ Phase error
- ▮ Frequency error (GMSK modulation scheme)
- ▮ Spectrum due to modulation
- ▮ Spectrum due to switching

³⁾ R&S®Multi-Evaluation List mode supported in combination with R&S®CMW-KM012 option.

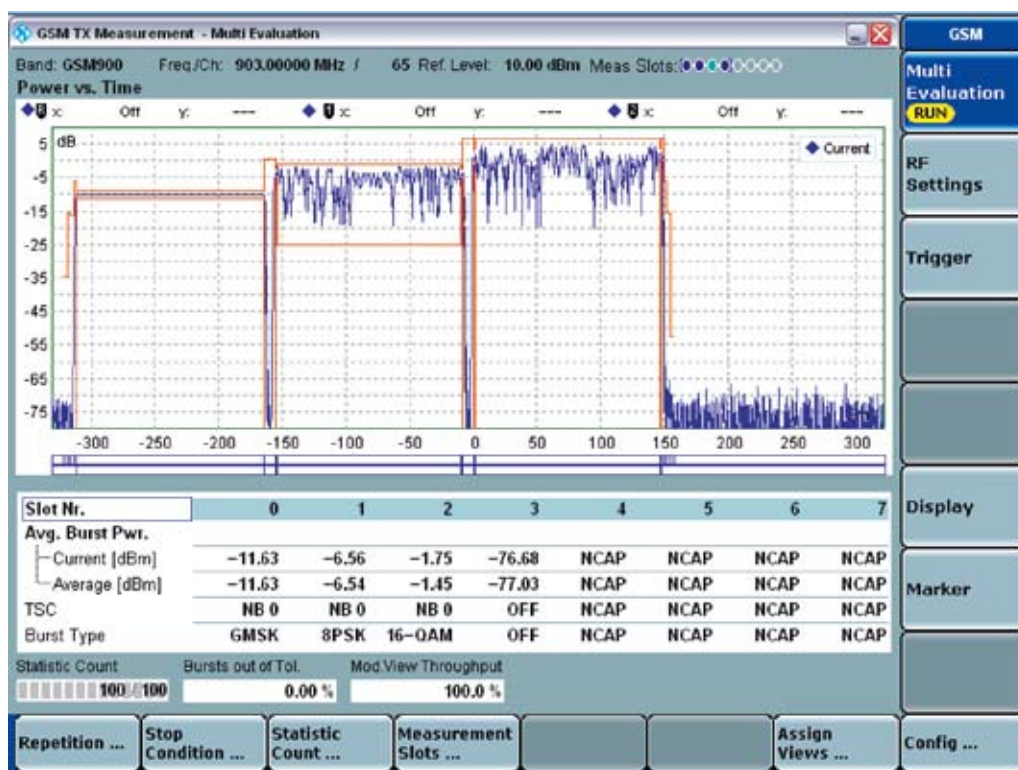

Time mask screen:
GSM/GPRS/EDGE/EDGE Evolution
TX measurement.

EDGE Evolution/ EGRS2-A extensions

R&S®CMW-KM202 measurement personality

- ▮ Enables measurements for 16QAM modulation schemes



Modulation analysis screen:
EDGE Evolution TX measurement.

WCDMA

R&S®CMW-KM400 measurement personality ³⁾

- ▮ UE power measurements can be applied to OFF/max./min. power
- ▮ Error vector magnitude
- ▮ Magnitude error
- ▮ Phase error
- ▮ I/Q origin offset/imbalance
- ▮ Frequency error
- ▮ Phase discontinuity
- ▮ Adjacent channel leakage ratio
- ▮ Spectrum emission mask
- ▮ Occupied bandwidth
- ▮ Code domain power
- ▮ Peak code domain error
- ▮ Code domain error
- ▮ Code domain power monitor
- ▮ Code domain error monitor



Overview screen:
WCDMA TX measurement –
R&S®Multi-Evaluation.

HSPA extensions

R&S®CMW-KM401 measurement personality

- ▮ Half-slot measurements
- ▮ Modulation analysis of HSPA channels
- ▮ Code domain power measurement of HSPA channels
- ▮ Code domain error versus slot measurement of HSPA channels
- ▮ HS-DPCCH power control
- ▮ Phase discontinuity

HSPA+ extensions

R&S®CMW-KM403 measurement personality

- ▮ 16QAM modulation analysis
- ▮ Relative code domain error

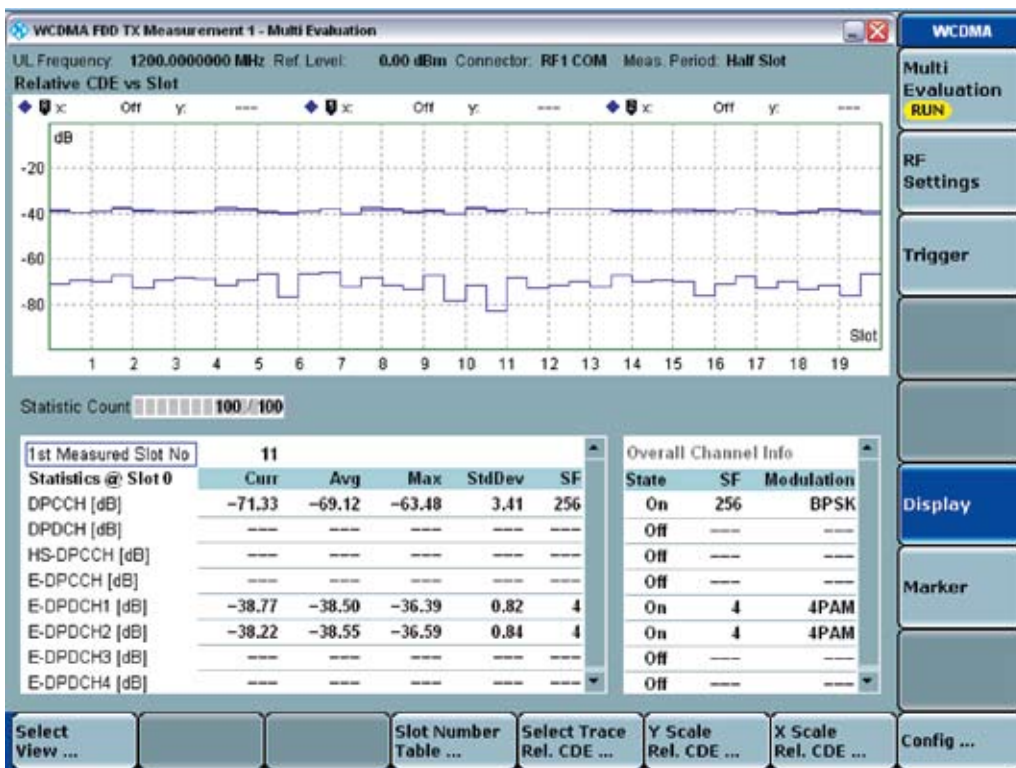

Overview screen:
relative CDE vs. slot measurement screen of 16QAM signal (two 4PAM channels in I and Q path).

LTE FDD

R&S®CMW-KM500 measurement personality

- ▮ Transmit power
- ▮ Peak power
- ▮ Resource block power
- ▮ Error vector magnitude
- ▮ Magnitude error
- ▮ Phase error
- ▮ Frequency error
- ▮ I/Q origin offset
- ▮ I/Q constellation diagram
- ▮ In-band emissions
- ▮ Spectrum flatness
- ▮ Adjacent channel leakage ratio
- ▮ Occupied bandwidth
- ▮ Spectrum emission mask



Overview screen:
LTE FDD TX measurement –
R&S®Multi-Evaluation.

LTE TDD (TD-LTE)

R&S®CMW-KM550 measurement personality

- ▮ Transmit power
- ▮ Peak power
- ▮ Resource block power
- ▮ Error vector magnitude
- ▮ Magnitude error
- ▮ Phase error
- ▮ Frequency error
- ▮ I/Q origin offset
- ▮ I/Q constellation diagram
- ▮ In-band emissions
- ▮ Spectrum flatness
- ▮ Adjacent channel leakage ratio
- ▮ Occupied bandwidth
- ▮ Spectrum emission mask

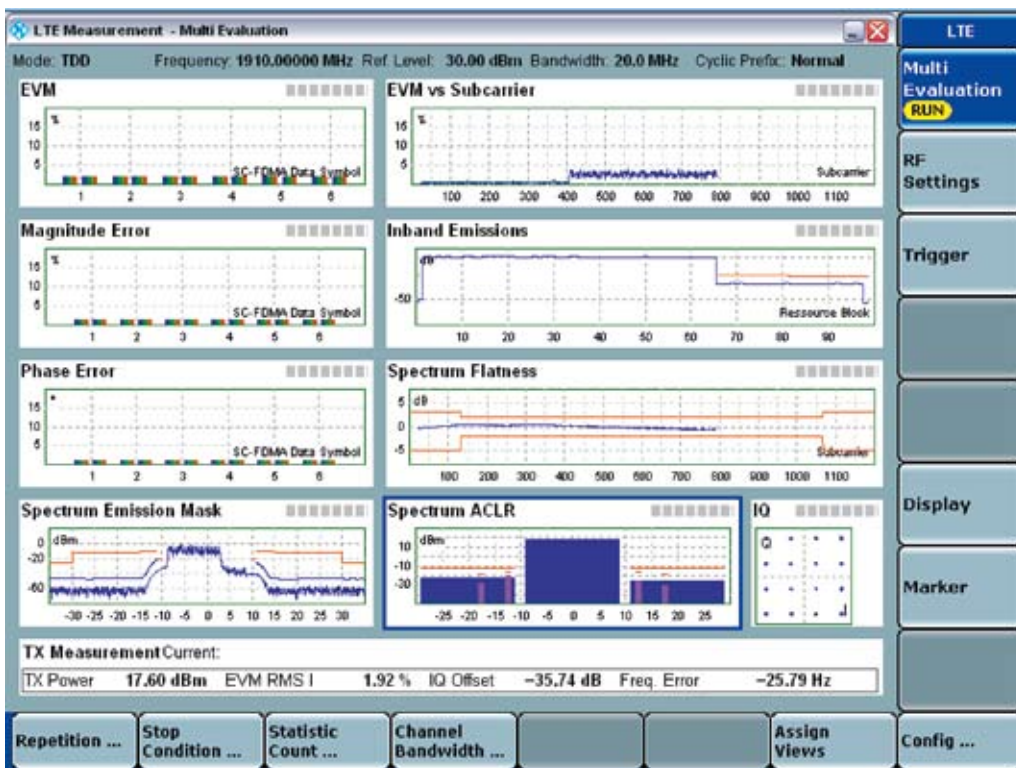

Overview screen:
LTE TDD TX measurement –
R&S®Multi-Evaluation.

CDMA2000[®] 1xRTT

R&S[®]CMW-KM800 measurement personality

- MS power
- Error vector magnitude
- Magnitude error
- Phase error
- Frequency error
- Carrier feedthrough
- I/Q imbalance
- Waveform quality
- Adjacent channel power
- Code domain power
- Code domain error power

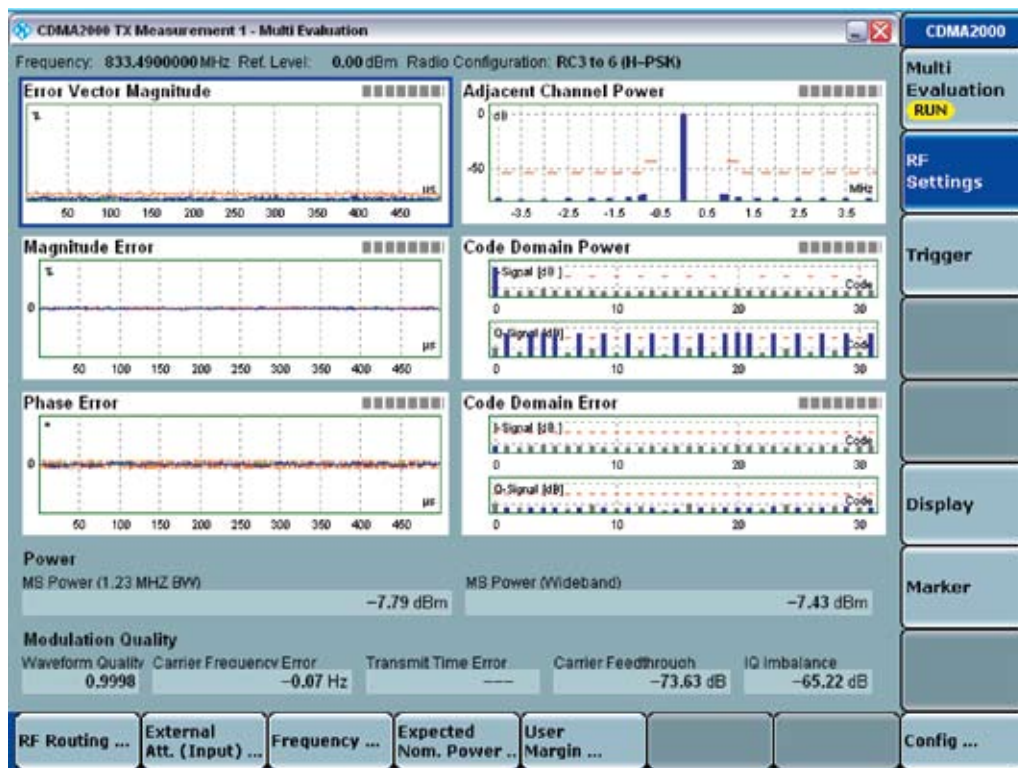

Overview screen:
CDMA2000[®] 1xRTT
TX measurement –
R&S[®]Multi-Evaluation.

CDMA2000[®] 1xEV-DO (Rel. 0 & Rev. A & Rev. B)

R&S[®]CMW-KM880 measurement personality

- ▮ MS power
- ▮ Error vector magnitude
- ▮ Magnitude error
- ▮ Phase error
- ▮ Frequency error
- ▮ Carrier feedthrough
- ▮ I/Q imbalance
- ▮ Waveform quality
- ▮ Adjacent channel power
- ▮ Code domain power
- ▮ Code domain error power



Overview screen:
CDMA2000[®] 1xEV-DO
TX measurement –
R&S[®]Multi-Evaluation.

Mobile WiMAX™

R&S®CMW-KM700 measurement personality

- ▮ Burst power
- ▮ Time mask
- ▮ Crest factor
- ▮ Subcarrier power
- ▮ Center frequency error
- ▮ Error vector magnitude (unmodulated)
- ▮ I/Q offset/imbalance
- ▮ Gain imbalance
- ▮ Quadrature error
- ▮ Sample clock error
- ▮ Spectral flatness (neighbor)
- ▮ Occupied bandwidth
- ▮ Adjacent channel power
- ▮ Spectrum emission mask



Overview screen:
Mobile WiMAX™ TX measure-
ment – R&S®Multi-Evaluation
(R&S®CMW-KM701 option).

TD-SCDMA

R&S®CMW-KM750 measurement personality

- ▮ UE power
- ▮ Transmit ON/OFF time mask
- ▮ Error vector magnitude
- ▮ Magnitude error
- ▮ Phase error
- ▮ Frequency error
- ▮ I/Q origin offset
- ▮ I/Q imbalance
- ▮ Waveform quality
- ▮ Adjacent channel leakage ratio
- ▮ Spectrum emission mask
- ▮ Occupied bandwidth
- ▮ Code domain power
- ▮ Code domain error power
- ▮ Code domain monitor

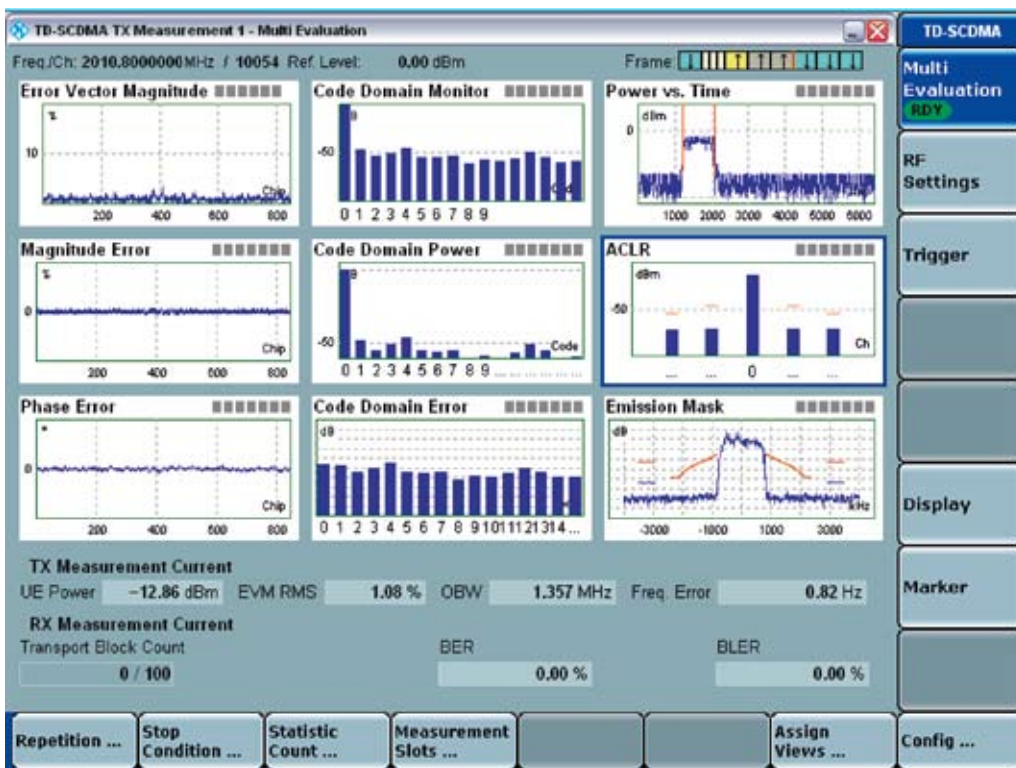

Overview screen:
TD-SCDMA TX measurement –
R&S®Multi-Evaluation.

Bluetooth®

R&S®CMW-KM610 measurement personality

Basic rate:

- ▮ Nominal power
- ▮ Frequency accuracy
- ▮ Frequency drift and max. drift rate
- ▮ Frequency deviation
- ▮ Spectrum: 20 dB bandwidth
- ▮ Spectrum: adjacent channel power

Enhanced data rate:

- ▮ Nominal power (GFSK, DPSK)
- ▮ Frequency stability ω_i
- ▮ Frequency stability ω_{0max}
- ▮ Differential error vector magnitude
- ▮ Phase difference graph
- ▮ I/Q constellation diagram

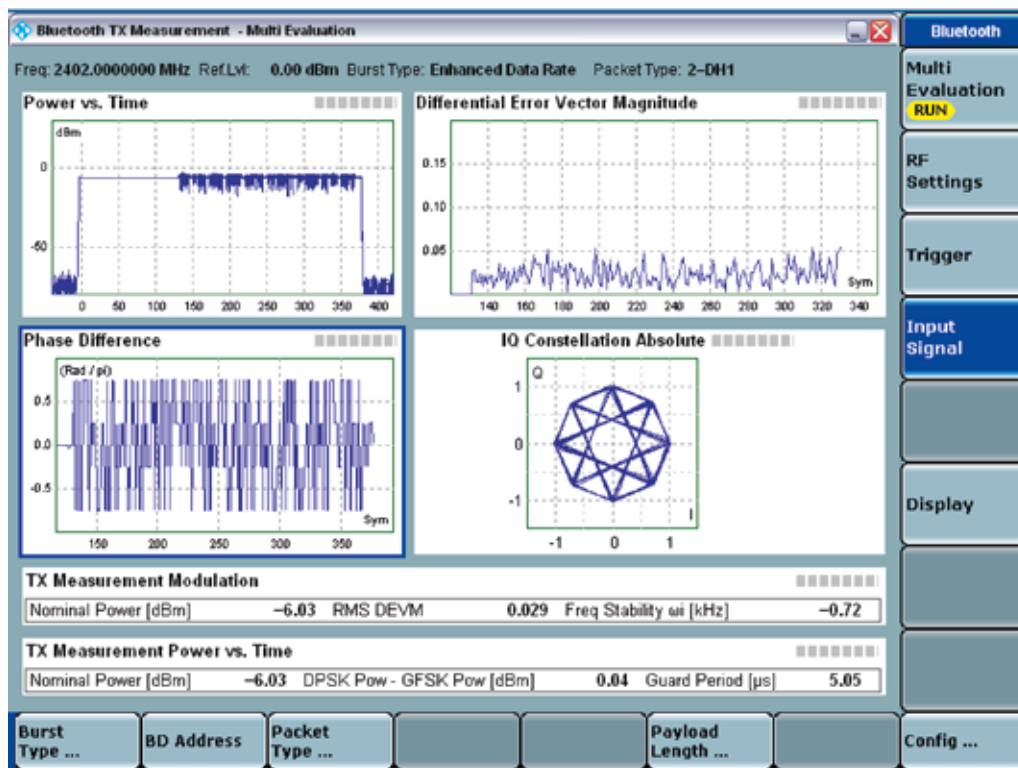

Bluetooth® TX measurement – R&S®Multi-Evaluation.

IEEE 802.11 a/b/g (WLAN)

R&S®CMW-KM650 measurement personality

- ▮ Burst power
- ▮ Center frequency error
- ▮ Symbol clock error, chip clock error
- ▮ Error vector magnitude
- ▮ I/Q constellation diagram
- ▮ Spectral flatness
- ▮ Transmit spectrum mask

IEEE 802.11 n extension

R&S®CMW-KM651 measurement personality³⁾

- ▮ Burst power
- ▮ Error vector magnitude
- ▮ Center frequency error
- ▮ Symbol clock error
- ▮ I/Q constellation diagram
- ▮ Spectral flatness
- ▮ Transmit spectrum mask

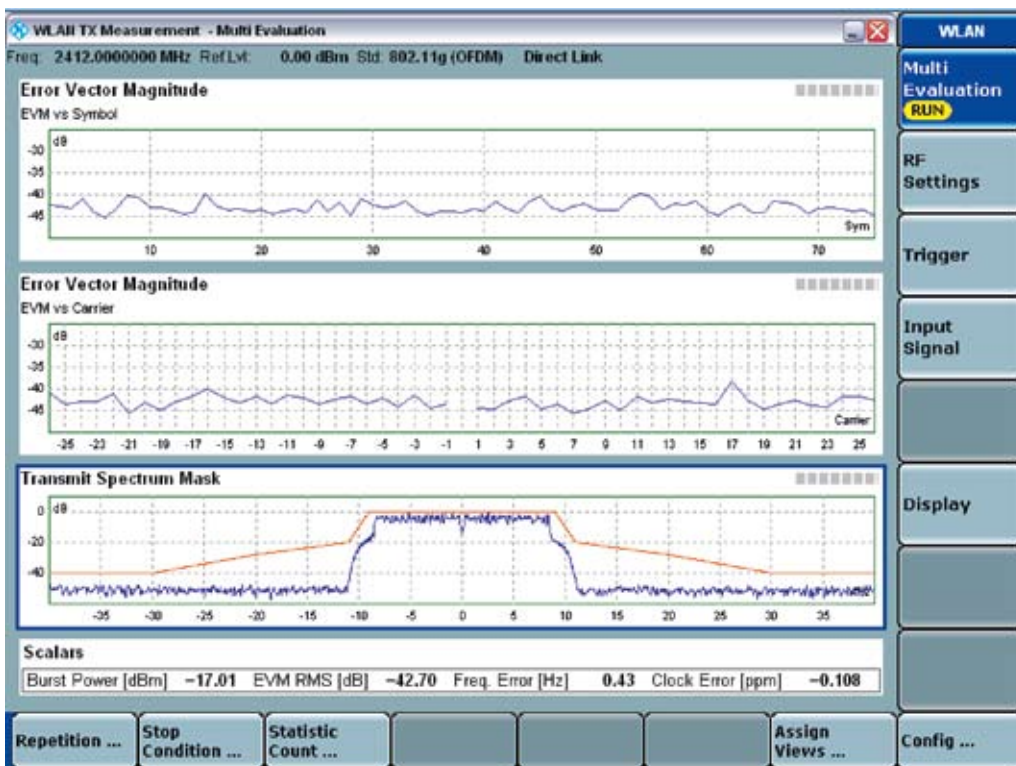

WLAN TX measurement –
R&S®Multi-Evaluation.

Recommended extra R&S®CMWrun sequencer software tool

The R&S®CMWrun sequencer software tool meets all needs for executing test sequences to remote-control the R&S®CMW500 in R&D, quality assurance and in the production of current and future wireless equipment.

The software engine is based on the execution of test DLLs (plug-in assemblies). This architecture not only allows easy and straightforward configuration of test sequences without knowledge of specific remote programming of the instrument. It also provides full flexibility in configuring parameters and limits of the test items provided in the R&S®CMWrun package options for the different standards.

Highlights

- Multitechnology solution
 - General-purpose applications (R&S®CMW-KT051 option)
 - GSM and WCDMA applications (R&S®CMW-KT053 option)
 - LTE applications (R&S®CMW-KT055 option)
 - Mobile WiMAX™ applications (R&S®CMW-KT057 option)
 - CDMA2000® 1xRTT/1xEV-DO applications (R&S®CMW-KT058 option)
- Ready-to-use solution, containing predefined Rohde&Schwarz applications for the technologies supported by the R&S®CMW500/R&S®CMW280
- Application programming interface (API)-based engine for easy and flexible integration of new applications
- Ease of use due to dedicated interfaces for operation, for editing sequences, for measurement reports and for debugging test sequences
- Application for SCPI remote control via LAN or GPIB interface

Ready-to-go solution with intuitive test plan configuration for different technologies.

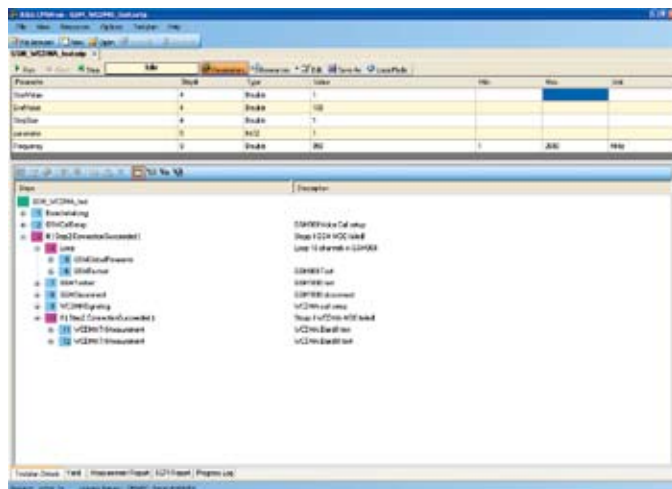

Straightforward display of signaling test reports with R&S®CMWrun.

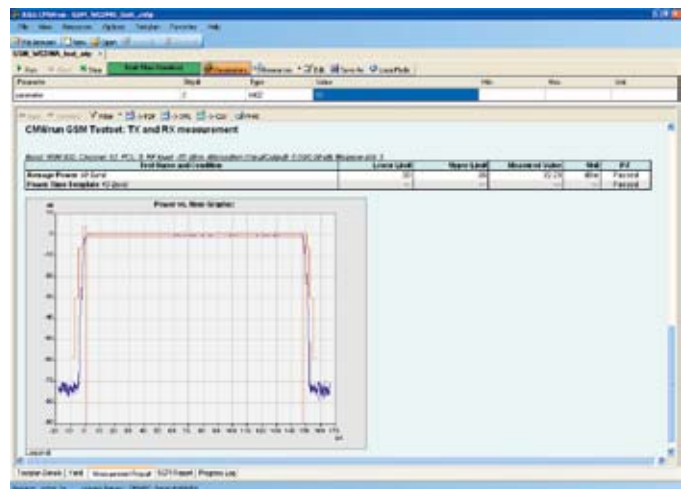

R&S®CMW500 specifications in brief

RF generator		
Frequency range	base model	70 MHz to 3300 MHz
	with R&S®CMW-KB036 option	70 MHz to 6000 MHz
Output level range		
RF1 COM, RF2 COM	100 MHz to 3300 MHz	
	continuous wave (CW)	-130 dBm to -5 dBm
	peak envelope power (PEP)	up to -5 dBm
	overranging (PEP)	up to 0 dBm
RF1 OUT	100 MHz to 3300 MHz	
	continuous wave (CW)	-120 dBm to +8 dBm
	peak envelope power (PEP)	up to +8 dBm
	overranging (PEP)	up to +13 dBm
Output level uncertainty		
	in temperature range +20°C to +35°C, no overranging	
RF1 COM, RF2 COM	output level > -120 dBm	
	100 MHz to 3300 MHz	< 0.6 dB
RF1 OUT	output level > -110 dBm	
	100 MHz to 3300 MHz	< 0.8 dB

Modulation source: arbitrary waveform generator (ARB) (R&S®CMW-B110A option)		
Memory size		1024 Gbyte
Word length	I	16 bit
	Q	16 bit
	marker	4 bit to 16 bit
Sample length	with 4-bit marker	up to 227.55 Msample
Sample rate	minimum	400 Hz
	maximum	100 MHz

RF power meter		
Frequency range	base model	70 MHz to 3300 MHz
	with R&S®CMW-KB036 option	70 MHz to 6000 MHz
Expected nominal power setting range		
RF1 COM, RF2 COM	100 MHz to 3300 MHz	-47 dBm to +34 dBm
Level uncertainty		
RF1 COM, RF2 COM	100 MHz to 3300 MHz	< 0.5 dB

General data		
Dimensions	W × H × D	465.1 mm × 197.3 mm × 517.0 mm (18.31 in × 7.77 in × 20.35 in) (19" 1/1, 4 HU, 450)
Weight	with typical options (single tester)	approx. 18 kg (approx. 39.68 lb)
Calibration interval	12 months	recommended for highest accuracy, see specified RF generator and RF analyzer level uncertainty
	24 months	add 0.2 dB to specified RF generator and RF analyzer level uncertainty

Ordering information

Designation	Type	Order No.	R&S®CMW500		R&S®CMW280
			Single (qty.)	Dual (qty.)	Single (qty.)
Model, mandatory					
Wideband Radio Communication Tester	R&S®CMW500	1201.0002K50	1	1	–
Wideband Radio Communication Tester	R&S®CMW280	1201.0002K25	–	–	1
Basic assembly, mandatory					
R&S®CMW500 Wideband Radio Communication Tester, Basic Assembly	R&S®CMW-PS502	1202.5408.02	1	1	–
R&S®CMW280 Wideband Radio Communication Tester, Basic Assembly	R&S®CMW-PS280	1202.7300.02	–	–	1
Selections, one out of two items to be selected, mandatory					
Baseband Interconnection Board (fixed link)	R&S®CMW-S550A	1202.4801.02	1	1	–
Baseband Interconnection Board (flexible link); alternatively, required for signaling	R&S®CMW-S550B	1202.4801.03	1	1	–
R&S®CMW500 Front Panel without Display/Keypad (contains DVI interface)	R&S®CMW-S600A	1201.0102.02	1	1	–
R&S®CMW500 Front Panel with Display/Keypad, alternatively	R&S®CMW-S600B	1201.0102.03	1	1	–
R&S®CMW280 Front Panel without Display/Keypad (contains DVI interface)	R&S®CMW-S600E	1201.0102.06	–	–	1
R&S®CMW280 Front Panel with Display/Keypad, alternatively	R&S®CMW-S600F	1201.0102.07	–	–	1
RF Frontend Module	R&S®CMW-S590A	1202.5108.02	1	1	1
Hardware configuration, optional					
ARB + Realtime Baseband Generator Module	R&S®CMW-B110A	1202.5508.02	1	2	1
Extra Baseband Measurement Unit	R&S®CMW-B100A	1202.8607.02	–	1	–
Extra RF Converter Module (TRX)	R&S®CMW-B570B	1202.8659.03	1	1	–
Extra RF Frontend Module	R&S®CMW-B590A	1202.8707.02	1	1	–
IEEE Bus Interface Module (single connector)	R&S®CMW-B612A	1202.5608.02	1	–	1
IEEE Bus Interface Module (dual connector), alternatively	R&S®CMW-B612B	1202.5708.02	1	1	–
Digital Video Interface (DVI) Module (only required for units with display/keypad)	R&S®CMW-B620A	1202.5808.02	1	1	1
Ocxo Module	R&S®CMW-B690A	1202.5908.02	1	1	1
Ocxo Module (highly stable), alternatively	R&S®CMW-B690B	1202.6004.02	1	1	1
Extended Frequency Range 3.3 GHz to 6 GHz (per RF channel/TRX)	R&S®CMW-KB036	1203.0851.02	up to 2	2	1
Signaling configuration for WCDMA, LTE, optional					
Signaling Unit, Wideband (SUW)	R&S®CMW-B300A	1202.6304.02	1	–	1
Signaling (network emulation), WCDMA	R&S®CMW-KS400	1204.0751.02	1	–	1
R&D Signaling Extension (network emulation) of R&S®CMW-KS400, WCDMA	R&S®CMW-KS410	1203.9807.02	1	–	1
Signaling (network emulation), LTE FDD	R&S®CMW-KS500	1203.6108.02	1	–	–
Signaling configuration for GSM/GPRS/EDGE, CDMA2000® 1xRTT, 1xEV-DO, Mobile WiMAX™ (one out of two to be selected: 1xEV-DO or WiMAX™), optional					
Signaling Unit, Universal (SUU)	R&S®CMW-B200A	1202.6104.02	1	–	1
GSM/GPRS/EDGE Signaling Extension Module	R&S®CMW-B210A	1202.6204.02	1	–	1
Signaling (network emulation), GSM/GPRS/EDGE	R&S®CMW-KS200	1203.0600.02	1	–	1
CDMA Signaling Extension Module	R&S®CMW-B220A	1202.7800.02	1	–	–
Signaling (network emulation), CDMA2000® 1xRTT	R&S®CMW-KS800	1203.3109.02	1	–	–
1xEV-DO Signaling Extension Module	R&S®CMW-B230A	1202.7600.02	1	–	–
Signaling (network emulation), CDMA2000® 1xEV-DO	R&S®CMW-KS880A	1203.3209.02	1	–	–
WiMAX™ Signaling Extension Module	R&S®CMW-B270A	1202.6504.02	1	–	–
Signaling (BS emulation), WiMAX™ (IEEE802.16e)	R&S®CMW-KS700	1202.6704.02	1	–	–

Designation	Type	Order No.	R&S®CMW500		R&S®CMW280
			Single (qty.)	Dual (qty.)	Single (qty.)
TX measurement configuration, optional					
FFT Spectrum Analyzer	R&S®CMW-KM010	1203.5953.02	1	2	1
TX Measurement, I/Q versus Slot	R&S®CMW-KM011	1203.0800.02	1	2	1
TX Measurement, R&S®Multi-Evaluation List Mode	R&S®CMW-KM012	1203.4457.02	1	2	1
TX Measurement, GSM/GPRS/EDGE, Uplink	R&S®CMW-KM200	1203.0551.02	1	2	1
TX Measurement, EDGE Evolution Extension of R&S®CMW-KM200, Uplink	R&S®CMW-KM201	1204.8404.02	1	2	1
TX Measurement, WCDMA, Uplink	R&S®CMW-KM400	1203.0700.02	1	2	1
TX Measurement, WCDMA HSPA Extension of R&S®CMW-KM400, Uplink	R&S®CMW-KM401	1203.2954.02	1	2	1
TX Measurement, WCDMA HSPA+ Extension of R&S®CMW-KM401, Uplink	R&S®CMW-KM403	1203.9007.02	1	2	1
TX Measurement, LTE FDD, Uplink	R&S®CMW-KM500	1203.5501.02	1	2	1
TX Measurement, LTE TDD (TD-LTE), Uplink	R&S®CMW-KM550	1203.8952.02	1	2	1
TX Measurement, Bluetooth®, Basic Rate and EDR	R&S®CMW-KM610	1203.6350.02	1	2	1
TX Measurement, FM Stereo Radio	R&S®CMW-KM645	1204.8804.02	1	2	1
TX Measurement, WLAN (IEEE 802.11 a/b/g)	R&S®CMW-KM650	1203.1658.02	1	2	1
TX Measurement, WLAN (IEEE 802.11 n) SISO Extension of R&S®CMW-KM650	R&S®CMW-KM651	1203.9159.02	1	2	1
TX Measurement, Mobile WiMAX™ (IEEE 802.16e)	R&S®CMW-KM700	1202.6604.02	1	2	1
TX Measurement, Mobile WiMAX™ (IEEE 802.16e), R&D Extension of R&S®CMW-KM700	R&S®CMW-KM701	1202.6610.02	1	2	1
TX Measurement, TD-SCDMA, Uplink	R&S®CMW-KM750	1203.2554.02	1	2	1
TX Measurement, CDMA2000® 1xRTT, Reverse Link	R&S®CMW-KM800	1203.2602.02	1	2	1
TX Measurement, 1xEV-DO, Reverse Link	R&S®CMW-KM880	1203.2854.02	1	2	1
Enable R&S®WinIQSIM2™ waveforms for ARB generator, optional					
Enable R&S®WinIQSIM2™ Waveforms, AWGN	R&S®CMW-KW010	1204.9000.02	1	2	1
Enable R&S®WinIQSIM2™ Waveforms, GSM/EDGE	R&S®CMW-KW200	1203.0951.02	1	2	1
Enable R&S®WinIQSIM2™ Waveforms, EDGE Evolution Extension of R&S®CMW-KW200	R&S®CMW-KW201	1204.8456.02	1	2	1
Enable R&S®WinIQSIM2™ Waveforms, WCDMA	R&S®CMW-KW400	1203.1006.02	1	2	1
Enable R&S®WinIQSIM2™ Waveforms, WCDMA, HSDPA Extension of R&S®CMW-KG400	R&S®CMW-KW401	1203.1058.02	1	2	1
Enable R&S®WinIQSIM2™ Waveforms, WCDMA, HSUPA Extension of R&S®CMW-KG401	R&S®CMW-KW402	1203.1106.02	1	2	1
Enable R&S®WinIQSIM2™ Waveforms, WCDMA, HSPA+ Extension of R&S®CMW-KW401 or R&S®CMW-KW402	R&S®CMW-KW403	1203.9059.02	1	2	1
Enable R&S®WinIQSIM2™ Waveforms, LTE FDD and LTE TDD (TD-LTE)	R&S®CMW-KW500	1203.5553.02	1	2	1
Enable R&S®WinIQSIM2™ Waveforms, Bluetooth®, Basic Rate and EDR	R&S®CMW-KW610	1203.6408.02	1	2	1
Enable R&S®WinIQSIM2™ Waveforms, GPS	R&S®CMW-KW620	1203.6008.02	1	2	1
Enable R&S®WinIQSIM2™ Waveforms, DVB	R&S®CMW-KW630	1203.6050.02	1	2	1
Enable R&S®WinIQSIM2™ Waveforms, WLAN (IEEE 802.11 a/b/g)	R&S®CMW-KW650	1203.1258.02	1	2	1
Enable WinIQSIM2™ Waveforms, WLAN (IEEE 802.11 n) Extension of R&S®CMW-KW650	R&S®CMW-KW651	1203.9259.02	1	2	1
Enable R&S®WinIQSIM2™ Waveforms, WiMAX™ (IEEE 802.16)	R&S®CMW-KW700	1203.1358.02	1	2	1
Enable R&S®WinIQSIM2™ Waveforms, TD-SCDMA	R&S®CMW-KW750	1203.1406.02	1	2	1
Enable R&S®WinIQSIM2™ Waveforms, TD-SCDMA Enhancements	R&S®CMW-KW751	1203.1458.02	1	2	1
Enable R&S®WinIQSIM2™ Waveforms, CDMA2000® 1xRTT	R&S®CMW-KW800	1203.1506.02	1	2	1
Enable R&S®WinIQSIM2™ Waveforms, CDMA2000® 1xEV-DO	R&S®CMW-KW880	1203.1558.02	1	2	1

Designation	Type	Order No.	R&S®CMW500		R&S®CMW280
			Single (qty.)	Dual (qty.)	Single (qty.)
Rohde & Schwarz waveform libraries for ARB generator, optional					
Waveforms, T-DMB, I/Q Stream with Video/Audio Content	R&S®CMW-KV634	1204.8004.02	1	2	1
Waveforms, MediaFLO™, I/Q Stream with Video/Audio Content	R&S®CMW-KV636	1204.8056.02	1	2	1
Waveforms, CMMB, I/Q Stream with Video/Audio Content	R&S®CMW-KV638	1204.8104.02	1	2	1
Waveforms, FM Stereo Radio	R&S®CMW-KV645	1204.8956.02	1	2	1
Online generator configuration, optional					
Generator, GSM/GPRS/EDGE, Downlink	R&S®CMW-KG200	1203.0500.02	1	2	1
Generator, WCDMA, Downlink	R&S®CMW-KG400	1203.0651.02	1	2	1
Generator, WCDMA HSPA Extension of R&S®CMW-KG400, Downlink	R&S®CMW-KG401	1203.2902.02	1	2	1
Generator, CDMA2000® 1xRTT, Forward Link	R&S®CMW-KG800	1203.3050.02	1	2	1
Sequencer software tool, optional					
R&S®CMWrun Sequencer Software Tool, General Purpose	R&S®CMW-KT051	1203.4157.02	1	2	1
R&S®CMWrun Sequencer Software Tool, GSM and WCDMA	R&S®CMW-KT053	1204.8156.02	1	2	1
R&S®CMWrun Sequencer Software Tool, LTE	R&S®CMW-KT055	1207.2107.02	1	2	1
R&S®CMWrun Sequencer Software Tool, WiMAX™	R&S®CMW-KT057	1203.4205.02	1	2	1
R&S®CMWrun Sequencer Software Tool, CDMA2000® 1xRTT/1xEV-DO	R&S®CMW-KT058	1207.2159.02	1	2	1

Recommended extras and power sensors

Designation	Type	Order No.
LC TFT Display, 17", 1280 × 1024, DVI-D and Analog Interface	R&S®PMC3	1082.6004.12
Keyboard with USB Interface (US character set)	R&S®PSL-Z2	1157.6870.04
Mouse with USB Interface (optical, with wheel)	R&S®PSL-Z10	1157.7060.04
19" Adapter, 4 HU, 1/1 for Design 2000 Cabinets	R&S®ZZA-411	1096.3283.00
Average Power Sensor for Universal Use, 10 MHz to 18 GHz, 200 pW to 200 mW	R&S®NRP-Z21	1137.6000.02
Power Sensor Module, DC to 18 GHz	R&S®NRP-Z27	1169.4102.02
Level Control Sensor, 10 MHz to 18 GHz, for Signal Generators	R&S®NRP-Z28	1170.8008.02
Documentation of Calibration Values	R&S®DCV-2	0240.2193.08

PC-based R&S®CMW applications for RF testing

Designation	Type	Order No.
Mandatory		
USB Smartcard for PC-Based R&S®CMW Applications	R&S®CMW-S089A	1202.7900.02
Optional		
R&S®CMWrun Sequencer Software Tool, General Purpose	R&S®CMW-KT051	1203.4157.02
R&S®CMWrun Sequencer Software Tool, GSM and WCDMA	R&S®CMW-KT053	1204.8156.02
R&S®CMWrun Sequencer Software Tool, LTE	R&S®CMW-KT055	1207.2107.02
R&S®CMWrun Sequencer Software Tool, WiMAX™	R&S®CMW-KT057	1203.4205.02
R&S®CMWrun Sequencer Software Tool, CDMA2000® 1xRTT/1xEV-DO	R&S®CMW-KT058	1207.2159.02

Your local Rohde & Schwarz expert will help you determine the optimum solution for your requirements.

To find your nearest Rohde & Schwarz representative, visit
www.sales.rohde-schwarz.com

Glossary

Term	Explanation
ACLR	Adjacent channel leakage ratio
ACP	Adjacent channel power
Alignment	Wireless device production cycle consisting of calibration and verification
All-in-one architecture	Complete, highly integrated compact solution with assured measurement accuracy and optimum handling
ARB	Generally used abbreviation for arbitrary waveform generator functionality
ARB generator mode	Baseband generator mode where the modulation is implemented by means of precalculated waveforms stored in the ARB memory
ARB + realtime baseband generator module	Generator module that supports not only the classic ARB mode but also the generation of complex modulated signals in realtime
BB	Baseband
BER	Bit error ratio
Calibration	Wireless device production stage during which the transmit power steps and the RSSI steps are measured and compared to reference values. The correction factors obtained are stored in the wireless device. Other common designations: phasing, tuning, alignment
CW	Continuous wave
DSP	Digital signal processor
Dual tester	Device configuration including two analyzers and two generators each for simultaneous testing of two identical wireless devices
DUT	Device under test
DVI	Digital video interface
EMC	Electromagnetic compatibility
EVM	Error vector magnitude
GPRF	General-purpose radio frequency
GPRF List mode	Lists containing predefined levels and frequencies for GPRF generator/power meter test sequences
GUI	Graphical user interface
HW	Hardware
Loop BER test in non-signaling mode	Method for RX verification in production. This test is performed in non-signaling mode, i.e. without realtime network emulation. The bit error ratio is evaluated through postprocessing via the uplink
ME	Magnitude error
MMI	Man machine interface
OBW	Occupied bandwidth
Online generator mode	Baseband generator mode where complex modulated signals are generated in realtime; maximal operation is performed via MMI
Path correction	Method for increasing the measurement accuracy by taking into account the influence of frequency, temperature and level on the RF attenuation of the measurement path
PE	Phase error
PRBS	Pseudo random bit sequence
Press&Go	Turnkey, highly automated test functionality that is available at the press of a button
R&S®Multi-Evaluation	Transmitter measurement concept where different measurement parameters use identical raw data
R&S®Smart Alignment	Alignment concept where predefined identical test sequences in the DUT and in the tester reduce the data volume in the test system and significantly shorten the test time
R&S®Multi-Evaluation List mode	R&S®Smart Alignment method; fast TX verification based on predefined test sequences
RF	Radio frequency
RMC	Reference measurement channel
RSSI	Receiver signal strength indication
RX	Receiver
SEM	Spectrum emission mask
Single-ended BER test	Modern approach to receiver verification where the stimulating signal is provided by the measuring instrument and the BER is calculated in the DUT
Single tester	Device configuration for testing of a single wireless device
SW	Software
Verification	Wireless device production stage during which the most important transmit and receive parameters are checked after calibration
VSA	Vector signal analyzer
VSG	Vector signal generator

Service you can rely on

- ▮ Worldwide
- ▮ Local and personalized
- ▮ Customized and flexible
- ▮ Uncompromising quality
- ▮ Long-term dependability

About Rohde & Schwarz

Rohde & Schwarz is an independent group of companies specializing in electronics. It is a leading supplier of solutions in the fields of test and measurement, broadcasting, radiomonitoring and radiolocation, as well as secure communications. Established more than 75 years ago, Rohde & Schwarz has a global presence and a dedicated service network in over 70 countries. Company headquarters are in Munich, Germany.

Environmental commitment

- ▮ Energy-efficient products
- ▮ Continuous improvement in environmental sustainability
- ▮ ISO 14001-certified environmental management system

Certified Quality System
ISO 9001

Rohde & Schwarz GmbH & Co. KG

www.rohde-schwarz.com

Regional contact

- ▮ Europe, Africa, Middle East
+49 89 4129 137 74
customersupport@rohde-schwarz.com
- ▮ North America
1 888 TEST RSA (1 888 837 87 72)
customer.support@rsa.rohde-schwarz.com
- ▮ Latin America
+1 410 910 79 88
customersupport.la@rohde-schwarz.com
- ▮ Asia/Pacific
+65 65 13 04 88
customersupport.asia@rohde-schwarz.com